

# **GRIND-ALL Supply Ltd.**

## **Catalog**



**Custom Carbide Burs**

**Standard Length Shanks**

**Extended Length Shanks**

**Flexible Spring Shanks**

**Diamond Burs**

**Industrial Tools**

**Featuring...**

# **Burly Bur**

**Grind-All Supply Ltd. :: [www.grindall.ca](http://www.grindall.ca)**

# About Grind-All Supply Ltd.

## Grind-All Supply Ltd. - Supplying you with top quality carbide burs, diamond-coated burs, air tools, parts, and accessories.

Grind-All Supply Ltd. has been providing quality products to various industries for the past 10 years. We are proud of our reputation of outstanding customer service and quick delivery on all orders.

Our top quality North American made burs are created on top-of-the-line 6-axis CNC tool grinders.

We offer high quality industrial air tools for any application. Grind-All Supply has developed the unique Mini 4-Bolt and X-Treme chipping hammers. We offer a **pneumatic tool repair program** serviced by experienced mechanics.



### Carbide Bur Repair Program

Whether you have bent, broken, dull, or chipped burs, Grind-All Supply offers:

- Re-sharpening
- Re-conditioning chipped burs
- Re-braze broken heads
- Shank straightening

**We can fix your burs!**



## Grind-All Supply Ltd. specializes in custom burs!

Grind-All specializes in custom burs. Most carbide burs shown in following pages can be fitted with a variety of shanks. Also available are extra long shanks or flexible spring shanks any length in several diameters. Call for specific applications.

All burs available in standard width flutes or course flutes for heavy metal removal.



### Contact Information...

#### Canada

271-A Stephen St.  
Morden, Manitoba  
R6M 1V2

#### United States

1800 Hwy. 32 North  
Walhalla, North Dakota  
58282

**Ph:** (204) 822-9911

**Fax:** (204) 822-9912

**Email:** [info@grindall.ca](mailto:info@grindall.ca)

**Website:** <http://www.grindall.ca>



# Table of Contents

CARBIDE BURS		Page
Cylindrical - SA SERIES		4
Cylindrical End Cut - SB SERIES		5
Cylindrical Ball Nose - SC SERIES		6
Ball Shape - SD SERIES		7
Egg Shape - SE SERIES		8
Round Nose Tree - SF SERIES		9
Pointed Tree - SG SERIES		10
Flame Shape - SH SERIES		11
60° Included Angle - SJ SERIES		12
90° Included Angle - SK SERIES		12
14° Cone Radius End - SL SERIES		13
Pointed Cone - SM SERIES		14
Inverted Taper - SN SERIES		14
Port Burs, Notes		15
OTHER FEATURED PRODUCTS		
Diamond Burs		16
Carbide & Diamond Wheel Burs		16
Die Grinders & Flex Shafts		17
Chipping Hammers		18-19
Chipping Hammer Chisels		20-22
Scaling Hammers & Chisels		23

## Technical Information... *A definition of terms*



**Single Cut** - A general purpose cut designed for steel, cast iron, and other ferrous materials. It will give good material removal and work piece finish.



**Double Cut** - Chip size is reduced, allows for rapid stock removal and better operator control. Use on stainless steel and ferrous materials.



**Aluminum Cut** - Wide flutes for non-ferrous materials to ensure rapid stock removal with minimum chip loading.

## Dimensions...

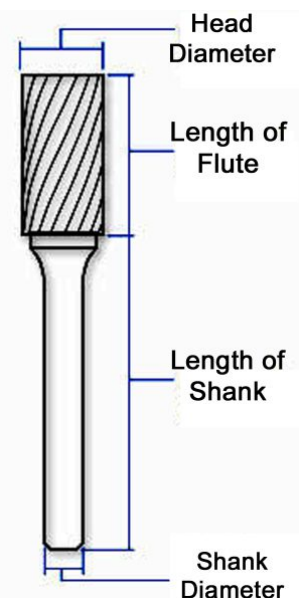

*All dimensions are in inches and fractional unless stated otherwise.*

# CYLINDRICAL - SA SERIES

# SA



SMOOTH END



Top Quality Carbide Burs from Grind-All Supply Ltd.

## STANDARD SHANK LENGTHS

HEAD SIZE (DIAMETER)	LENGTH OF CUT	OVERALL LENGTH	SINGLE CUT PART NUMBER	DOUBLE CUT PART NUMBER	ALUMINUM CUT PART NUMBER	SHANK DIAMETER
1/16	1/4	1-1/2	SA-61	SA-61D	-	3/32
3/32	3/8	1-1/2	SA-63	SA-63D	-	3/32
1/16	1/4	1-1/2	SA-41	SA-41D	-	1/8
1/16	1/4	2	SA-41L2	SA-41L2D	-	1/8
1/16	1/4	3	SA-41L3	SA-41L3D	-	1/8
3/32	7/16	1-1/2	SA-42	SA-42D	-	1/8
3/32	7/16	2	SA-42L2	SA-42L2D	-	1/8
3/32	7/16	3	SA-42L3	SA-42L3D	-	1/8
1/8	9/16	1-1/2	SA-43	SA-43D	-	1/8
1/8	9/16	2	SA-43L2	SA-43L2D	-	1/8
1/8	9/16	3	SA-43L3	SA-43L3D	-	1/8
5/32	1/2	2	SA-52	SA-52D	-	1/8
3/16	1/2	2	SA-53	SA-53D	-	1/8
1/4	1/2	2	SA-51	SA-51D	SA-51NF	1/8
3/16	1/2	2	SA-81	SA-81D	-	3/16
1/8	1/2	2	SA-11	SA-11D	-	1/4
1/8	5/8	2	SA-12	SA-12D	-	1/4
5/32	5/8	2	SA-13	SA-13D	-	1/4
3/16	5/8	2	SA-14	SA-14D	-	1/4
1/4	5/8	2	SA-1	SA-1D	SA-1NF	1/4
1/4	1	2	SA-1L	SA-1LD	-	1/4
5/16	3/4	2-1/2	SA-2	SA-2D	-	1/4
3/8	3/4	2-1/2	SA-3	SA-3D	SA-3NF	1/4
3/8	1	2-1/2	SA-3L	SA-3LD	-	1/4
3/8	1-1/2	3-1/4	SA-3X	SA-3XD	-	1/4
7/16	1	2-3/4	SA-4	SA-4D	-	1/4
1/2	1	2-3/4	SA-5	SA-5D	SA-5NF	1/4
5/8	1	2-3/4	SA-6	SA-6D	SA-6NF	1/4
3/4	1/2	2-3/4	SA-15	SA-15D	-	1/4
3/4	3/4	2-3/4	SA-16	SA-16D	-	1/4
3/4	1	2-3/4	SA-7	SA-7D	SA-7NF	1/4
7/8	1	2-3/4	SA-8	SA-8D	-	1/4
1	1	2-3/4	SA-9	SA-9D	-	1/4

**\*\* 3/8" shanks available \*\***

## EXTENDED SHANK LENGTHS

### 6" SHANK



HEAD SIZE (DIAMETER)	LENGTH OF CUT	OVERALL LENGTH	SINGLE CUT PART NUMBER	DOUBLE CUT PART NUMBER	ALUMINUM CUT PART NUMBER	SHANK DIAMETER
1/4	1/2	6-1/2	SA-1L6	SA-1L6D	-	1/4
3/8	3/4	6-3/4	SA-3L6	SA-3L6D	SA-3NF-6	1/4
1/2	1	7	SA-5L6	SA-5L6D	SA-5NF-6	1/4

**\*\* 3/8" shanks available \*\***

# CYLINDRICAL END CUT - SB SERIES

# SB



CUTTING END



## STANDARD SHANK LENGTHS

HEAD SIZE (DIAMETER)	LENGTH OF CUT	OVERALL LENGTH	SINGLE CUT PART NUMBER	DOUBLE CUT PART NUMBER	ALUMINUM CUT PART NUMBER	SHANK DIAMETER
1/16	1/4	1-1/2	SB-41	SB-41D	-	1/8
1/16	1/4	2	SB-41L2	SB-41L2D	-	1/8
1/16	1/4	3	SB-41L3	SB-41L3D	-	1/8
3/32	7/16	1-1/2	SB-42	SB-42D	-	1/8
3/32	7/16	2	SB-42L2	SB-42L2D	-	1/8
3/32	7/16	3	SB-42L3	SB-42L3D	-	1/8
1/8	9/16	1-1/2	SB-43	SB-43D	-	1/8
1/8	9/16	2	SB-43L2	SB-43L2D	-	1/8
1/8	9/16	3	SB-43L3	SB-43L3D	-	1/8
1/4	3/16	1-11/16	SB-51	SB-51D	-	1/8
1/8	1/2	2	SB-11	SB-11D	-	1/4
5/32	5/8	2	SB-13	SB-13D	-	1/4
3/16	5/8	2	SB-14	SB-14D	-	1/4
1/4	5/8	2	SB-1	SB-1D	SB-1NF	1/4
1/4	1	2	SB-1L	SB-1LD	-	1/4
5/16	3/4	2-1/2	SB-2	SB-2D	-	1/4
3/8	3/4	2-1/2	SB-3	SB-3D	SB-3NF	1/4
3/8	1	2-1/2	SB-3L	SB-3LD	-	1/4
3/8	1-1/2	3-1/4	SB-3X	SB-3XD	-	1/4
7/16	1	2-3/4	SB-4	SB-4D	-	1/4
1/2	1	2-3/4	SB-5	SB-5D	SB-5NF	1/4
5/8	1	2-3/4	SB-6	SB-6D	SB-6NF	1/4
3/4	1/2	2-3/4	SB-15	SB-15D	-	1/4
3/4	3/4	2-3/4	SB-16	SB-16D	-	1/4
3/4	1	2-3/4	SB-7	SB-7D	SB-7NF	1/4
7/8	1	2-3/4	SB-8	SB-8D	-	1/4
1	1	2-3/4	SB-9	SB-9D	-	1/4

\*\* 3/8" shanks available \*\*

Top Quality Carbide Burs from Grind-All Supply Ltd.



BEFORE

## Carbide Bur Repair Program

Contact us for details on our Carbide Bur repair and re-sharpening service - bent shanks, broken off heads, dull or chipped burs - we'll make your old burs like new!

**We can fix your burs!**



AFTER

# CYLINDRICAL BALL NOSE - SC SERIES

SC



Top Quality Carbide Burs from Grind-All Supply Ltd.

## STANDARD SHANK LENGTHS

HEAD SIZE (DIAMETER)	LENGTH OF CUT	OVERALL LENGTH	SINGLE CUT PART NUMBER	DOUBLE CUT PART NUMBER	ALUMINUM CUT PART NUMBER	SHANK DIAMETER
3/32	3/8	1-1/2	SC-61	SC-61D	-	3/32
3/32	7/16	1-1/2	SC-41	SC-41D	-	1/8
1/8	9/16	1-1/2	SC-42	SC-42D	-	1/8
1/8	9/16	2	SC-42L2	SC-42L2D	-	1/8
1/8	9/16	3	SC-42L3	SC-42L3D	-	1/8
5/32	1/2	2	SC-52	SC-52D	-	1/8
3/16	1/2	2	SC-53	SC-53D	-	1/8
1/4	1/2	2	SC-51	SC-51D	SC-51NF	1/8
3/16	1/2	2	SC-81	SC-81D	-	3/16
1/8	1/2	2	SC-11	SC-11D	-	1/4
1/8	5/8	2	SC-12	SC-12D	-	1/4
5/32	5/8	2	SC-13	SC-13D	-	1/4
3/16	5/8	2	SC-14	SC-14D	-	1/4
1/4	5/8	1-3/4	SC-1	SC-1D	SC-1NF	1/4
1/4	1	1-3/4	SC-1L	SC-1LD	-	1/4
5/16	3/4	2-1/2	SC-2	SC-2D	-	1/4
3/8	3/4	2-1/2	SC-3	SC-3D	SC-3NF	1/4
3/8	1	2-1/2	SC-3L	SC-3LD	-	1/4
3/8	1-1/2	3-1/4	SC-3X	SC-3XD	-	1/4
7/16	1	2-3/4	SC-4	SC-4D	-	1/4
1/2	1	2-3/4	SC-5	SC-5D	SC-5NF	1/4
5/8	1	2-3/4	SC-6	SC-6D	SC-6NF	1/4
3/4	1/2	2-3/4	SC-15	SC-15D	-	1/4
3/4	3/4	2-3/4	SC-16	SC-16D	-	1/4
3/4	1	2-3/4	SC-7	SC-7D	SC-7NF	1/4
1	1	2-3/4	SC-9	SC-9D	-	1/4

\*\* 3/8" shanks available \*\*

## EXTENDED SHANK LENGTHS

### 6" SHANK



HEAD SIZE (DIAMETER)	LENGTH OF CUT	OVERALL LENGTH	SINGLE CUT PART NUMBER	DOUBLE CUT PART NUMBER	ALUMINUM CUT PART NUMBER	SHANK DIAMETER
1/4	1/2	6-1/2	SC-1L6	SC-1L6D	-	1/4
3/8	3/4	6-3/4	SC-3L6	SC-3L6D	SC-3NF-6	1/4
1/2	1	7	SC-5L6	SC-5L6D	SC-5NF-6	1/4

\*\* 3/8" shanks available \*\*

# BALL SHAPE - SD SERIES

# SD



## STANDARD SHANK LENGTHS

HEAD SIZE (DIAMETER)	LENGTH OF CUT	OVERALL LENGTH	SINGLE CUT PART NUMBER	DOUBLE CUT PART NUMBER	ALUMINUM CUT PART NUMBER	SHANK DIAMETER
3/32	3/32	1-1/2	SD-61	SD-61D	-	3/32
3/32	3/32	1-1/2	SD-41	SD-41D	-	1/8
1/8	1/8	1-1/2	SD-42	SD-42D	-	1/8
1/8	1/8	2	SD-42L2	SD-42L2D	-	1/8
1/8	1/8	3	SD-42L3	SD-42L3D	-	1/8
5/32	5/32	1-5/8	SD-52	SD-52D	-	1/8
3/16	3/16	1-11/16	SD-53	SD-53D	-	1/8
1/4	7/32	1-11/16	SD-51	SD-51D	-	1/8
3/16	5/32	2	SD-81	SD-81D	-	3/16
1/8	3/32	2	SD-11	SD-11D	-	1/4
3/16	1/8	2	SD-14	SD-14D	-	1/4
1/4	7/32	2	SD-1	SD-1D	SD-1NF	1/4
5/16	1/4	2-1/32	SD-2	SD-2D	-	1/4
3/8	5/16	2-5/64	SD-3	SD-3D	SD-3NF	1/4
7/16	3/8	2-9/64	SD-4	SD-4D	-	1/4
1/2	7/16	2-13/64	SD-5	SD-5D	SD-5NF	1/4
5/8	9/16	2-5/16	SD-6	SD-6D	SD-6NF	1/4
3/4	11/16	2-7/16	SD-7	SD-7D	SD-7NF	1/4
1	15/16	2-11/16	SD-9	SD-9D	-	1/4

**\*\* 3/8" shanks available \*\***

**SD series burs are recommended for flex shanks. See page 17 for more details.**

## EXTENDED SHANK LENGTHS

### 6" SHANK

HEAD SIZE (DIAMETER)	LENGTH OF CUT	OVERALL LENGTH	SINGLE CUT PART NUMBER	DOUBLE CUT PART NUMBER	ALUMINUM CUT PART NUMBER	SHANK DIAMETER
1/4	1/2	6-1/2	SD-1L6	SD-1L6D	-	1/4
3/8	3/4	6-3/4	SD-3L6	SD-3L6D	SD-3NF-6	1/4
1/2	1	7	SD-5L6	SD-5L6D	SD-5NF-6	1/4

**\*\* 3/8" shanks available \*\***

Top Quality Carbide Burs from Grind-All Supply Ltd.

# EGG SHAPE - SE SERIES

SE



## STANDARD SHANK LENGTHS

HEAD SIZE (DIAMETER)	LENGTH OF CUT	OVERALL LENGTH	SINGLE CUT PART NUMBER	DOUBLE CUT PART NUMBER	ALUMINUM CUT PART NUMBER	SHANK DIAMETER
3/32	1/8	1-1/2	SE-61	SE-61D	-	3/32
1/8	7/32	1-1/2	SE-41	SE-41D	-	1/8
1/8	7/32	2	SE-41L2	SE-41L2D	-	1/8
1/8	7/32	3	SE-41L3	SE-41L3D	-	1/8
3/16	9/32	1-7/8	SE-53	SE-53D	-	1/8
1/4	3/8	1-7/8	SE-51	SE-51D	SE-51NF	1/8
3/16	9/32	2	SE-81	SE-81D	-	3/16
3/16	5/16	2	SE-11	SE-11D	-	1/4
1/4	3/8	2	SE-1	SE-1D	SE-1NF	1/4
3/8	5/8	2-3/8	SE-3	SE-3D	SE-3NF	1/4
1/2	7/8	2-5/8	SE-5	SE-5D	SE-5NF	1/4
5/8	1	2-3/4	SE-6	SE-6D	SE-6NF	1/4
3/4	1	2-3/4	SE-7	SE-7D	SE-7NF	1/4

\*\* 3/8" shanks available \*\*

Top Quality Carbide Burs from Grind-All Supply Ltd.

## Carbide Bur Repair Program

Contact us for details on our Carbide Bur repair and re-sharpening service - bent shanks, broken off heads, dull or chipped burs - we'll make your old burs like new!



BEFORE



AFTER

## EXTENDED SHANK LENGTHS

### 6" SHANK

HEAD SIZE (DIAMETER)	LENGTH OF CUT	OVERALL LENGTH	SINGLE CUT PART NUMBER	DOUBLE CUT PART NUMBER	ALUMINUM CUT PART NUMBER	SHANK DIAMETER
1/4	1/2	6-1/2	SE-1L6	SE-1L6D	-	1/4
3/8	3/4	6-3/4	SE-3L6	SE-3L6D	SE-3NF-6	1/4
1/2	1	7	SE-5L6	SE-5L6D	SE-5NF-6	1/4



\*\* 3/8" shanks available \*\*

# ROUND NOSE TREE - SF SERIES

# SF



## STANDARD SHANK LENGTHS

HEAD SIZE (DIAMETER)	LENGTH OF CUT	OVERALL LENGTH	SINGLE CUT PART NUMBER	DOUBLE CUT PART NUMBER	ALUMINUM CUT PART NUMBER	SHANK DIAMETER
3/32	1/4	1-1/2	SF-61	SF-61D	-	3/32
1/8	1/4	1-1/2	SF-41	SF-41D	-	1/8
1/8	1/2	1-1/2	SF-42	SF-42D	-	1/8
1/8	1/2	2	SF-42L2	SF-42L2D	-	1/8
1/8	1/2	3	SF-42L3	SF-42L3D	-	1/8
3/16	1/2	2	SF-53	SF-53D	-	1/8
1/4	1/2	2	SF-51	SF-51D	SF-51NF	1/8
3/16	1/2	2	SF-81	SF-81D	-	3/16
1/8	1/2	2	SF-11	SF-11D	-	1/4
1/4	5/8	2	SF-1	SF-1D	SF-1NF	1/4
3/8	3/4	2-1/2	SF-3	SF-3D	SF-3NF	1/4
7/16	1	2-3/4	SF-4	SF-4D	-	1/4
1/2	3/4	2-1/2	SF-13	SF-13D	-	1/4
1/2	1	2-3/4	SF-5	SF-5D	SF-5NF	1/4
5/8	1	2-3/4	SF-6	SF-6D	SF-6NF	1/4
3/4	1	2-3/4	SF-7	SF-7D	-	1/4
3/4	1-1/4	3	SF-14	SF-14D	SF-14NF	1/4
3/4	1-1/2	3	SF-15	SF-15D	-	1/4

\*\* 3/8" shanks available \*\*

## EXTENDED SHANK LENGTHS

### 6" SHANK



HEAD SIZE (DIAMETER)	LENGTH OF CUT	OVERALL LENGTH	SINGLE CUT PART NUMBER	DOUBLE CUT PART NUMBER	ALUMINUM CUT PART NUMBER	SHANK DIAMETER
1/4	1/2	6-1/2	SF-1L6	SF-1L6D	-	1/4
3/8	3/4	6-3/4	SF-3L6	SF-3L6D	SF-3NF-6	1/4
1/2	1	7	SF-5L6	SF-5L6D	SF-5NF-6	1/4

\*\* 3/8" shanks available \*\*

Top Quality Carbide Burs from Grind-All Supply Ltd.

# POINTED TREE - SG SERIES

SG



Top Quality Carbide Burs from Grind-All Supply Ltd.

## STANDARD SHANK LENGTHS

HEAD SIZE (DIAMETER)	LENGTH OF CUT	OVERALL LENGTH	SINGLE CUT PART NUMBER	DOUBLE CUT PART NUMBER	ALUMINUM CUT PART NUMBER	SHANK DIAMETER
3/32	1/4	1-1/2	SG-61	SG-61D	-	3/32
1/8	1/4	1-1/2	SG-41	SG-41D	-	1/8
1/8	5/16	1-1/2	SG-42	SG-42D	-	1/8
1/8	3/8	1-1/2	SG-43	SG-43D	-	1/8
1/8	1/2	1-1/2	SG-44	SG-44D	-	1/8
1/8	1/2	2	SG-44L2	SG-44L2D	-	1/8
1/8	1/2	3	SG-44L3	SG-44L3D	-	1/8
3/16	1/2	2	SG-53	SG-53D	-	1/8
1/4	1/2	2	SG-51	SG-51D	-	1/8
3/16	1/2	2	SG-81	SG-81D	-	3/16
1/4	5/8	2	SG-1	SG-1D	-	1/4
5/16	3/4	2-1/2	SG-2	SG-2D	-	1/4
3/8	3/4	2-1/2	SG-3	SG-3D	-	1/4
1/2	3/4	2-1/2	SG-13	SG-13D	-	1/4
1/2	1	2-3/4	SG-5	SG-5D	-	1/4
5/8	1	2-3/4	SG-6	SG-6D	-	1/4
3/4	1	2-3/4	SG-7	SG-7D	-	1/4
3/4	1-1/2	3-1/4	SG-15	SG-15D	-	1/4

\*\* 3/8" shanks available \*\*

## EXTENDED SHANK LENGTHS

### 6" SHANK



HEAD SIZE (DIAMETER)	LENGTH OF CUT	OVERALL LENGTH	SINGLE CUT PART NUMBER	DOUBLE CUT PART NUMBER	ALUMINUM CUT PART NUMBER	SHANK DIAMETER
1/4	1/2	6-1/2	SG-1L6	SG-1L6D	-	1/4
3/8	3/4	6-3/4	SG-3L6	SG-3L6D	-	1/4
1/2	1	7	SG-5L6	SG-5L6D	-	1/4

\*\* 3/8" shanks available \*\*

# FLAME SHAPE - SH SERIES

# SH



## STANDARD SHANK LENGTHS

HEAD SIZE (DIAMETER)	LENGTH OF CUT	OVERALL LENGTH	SINGLE CUT PART NUMBER	DOUBLE CUT PART NUMBER	ALUMINUM CUT PART NUMBER	SHANK DIAMETER
1/8	1/4	1-1/2	SH-41	SH-41D	-	1/8
1/8	1/4	2	SH-41L2	SH-41L2D	-	1/8
1/8	1/4	3	SH-41L3	SH-41L3D	-	1/8
3/16	3/8	2	SH-53	SH-53D	-	1/8
1/4	5/8	2	SH-1	SH-1D	-	1/4
5/16	3/4	2-1/2	SH-2	SH-2D	-	1/4
1/2	1-1/4	3	SH-5	SH-5D	SH-5NF	1/4
5/8	1-7/16	3-3/16	SH-6	SH-6D	-	1/4
3/4	1-5/8	3-3/8	SH-7	SH-7D	-	1/4

**\*\* 3/8" shanks available \*\***

Top Quality Carbide Burs from Grind-All Supply Ltd.



**BEFORE**

## Carbide Bur Repair Program

Contact us for details on our Carbide Bur repair and re-sharpening service - bent shanks, broken off heads, dull or chipped burs - we'll make your old burs like new!



**AFTER**

## EXTENDED SHANK LENGTHS

### 6" SHANK



HEAD SIZE (DIAMETER)	LENGTH OF CUT	OVERALL LENGTH	SINGLE CUT PART NUMBER	DOUBLE CUT PART NUMBER	ALUMINUM CUT PART NUMBER	SHANK DIAMETER
5/16	3/4	6-3/4	SH-2L6	SH-2L6D	-	1/4
1/2	1-1/4	7-1/4	SH-5L6	SH-5L6D	SH-5NF-6	1/4

**\*\* 3/8" shanks available \*\***

## 60° INCLUDED ANGLE - SJ SERIES

SJ



### STANDARD SHANK LENGTHS

HEAD SIZE (DIAMETER)	LENGTH OF CUT	OVERALL LENGTH	SINGLE CUT PART NUMBER	DOUBLE CUT PART NUMBER	ALUMINUM CUT PART NUMBER	SHANK DIAMETER
1/8	3/32	1-1/2	SJ-42	SJ-42D	-	1/8
1/4	3/16	2	SJ-1	SJ-1D	-	1/4
3/8	5/16	2-3/16	SJ-3	SJ-3D	-	1/4
1/2	7/16	2-19/64	SJ-5	SJ-5D	-	1/4
5/8	9/16	2-5/16	SJ-6	SJ-6D	-	1/4
3/4	11/16	2-7/16	SJ-7	SJ-7D	-	1/4
1	15/16	2-11/16	SJ-9	SJ-9D	-	1/4

\*\* 3/8" shanks available \*\*

## 90° INCLUDED ANGLE - SK SERIES

SK



### STANDARD SHANK LENGTHS

HEAD SIZE (DIAMETER)	LENGTH OF CUT	OVERALL LENGTH	SINGLE CUT PART NUMBER	DOUBLE CUT PART NUMBER	ALUMINUM CUT PART NUMBER	SHANK DIAMETER
1/8	1/16	1-1/2	SK-42	SK-42D	-	1/8
1/4	1/8	2	SK-1	SK-1D	-	1/4
3/8	3/16	2-1/16	SK-3	SK-3D	-	1/4
1/2	1/4	2-1/8	SK-5	SK-5D	-	1/4
5/8	5/16	2-3/16	SK-6	SK-6D	-	1/4
3/4	3/8	2-1/4	SK-7	SK-7D	-	1/4
1	1/2	2-1/4	SK-9	SK-9D	-	1/4

\*\* 3/8" shanks available \*\*

# 14° CONE RADIUS END - SL SERIES

# SL



STANDARD SHANK LENGTHS						
HEAD SIZE (DIAMETER)	LENGTH OF CUT	OVERALL LENGTH	SINGLE CUT PART NUMBER	DOUBLE CUT PART NUMBER	ALUMINUM CUT PART NUMBER	SHANK DIAMETER
1/8	3/8	1-1/2	SL-41	SL-41D	-	1/8
1/8	1/2	1-1/2	SL-42	SL-42D	-	1/8
1/8	1/2	2	SL-42L2	SL-42L2D	-	1/8
1/8	1/2	3	SL-42L3	SL-42L3D	-	1/8
3/16	1/2	2	SL-53	SL-53D	-	1/8
3/16	7/16	2	SL-81	SL-81D	-	3/16
1/4	5/8	2	SL-1	SL-1D	SL-1NF	1/4
5/16	7/8	2-3/4	SL-2	SL-2D	-	1/4
3/8	1-1/16	2-15/16	SL-3	SL-3D	SL-3NF	1/4
1/2	1-1/8	3	SL-4	SL-4D	SL-4NF	1/4
5/8	1-3/16	3-1/16	SL-5	SL-5D	SL-5NF	1/4
5/8	1-5/16	3-3/16	SL-6	SL-6D	SL-6NF	1/4
3/4	1-1/2	3-3/8	SL-7	SL-7D	SL-7NF	1/4

**\*\* 3/8" shanks available \*\***

Top Quality Carbide Burs from Grind-All Supply Ltd.



**BEFORE**

## Carbide Bur Repair Program

Contact us for details on our Carbide Bur repair and re-sharpening service - bent shanks, broken off heads, dull or chipped burs - we'll make your old burs like new!



**AFTER**

## EXTENDED SHANK LENGTHS

### 6" SHANK



HEAD SIZE (DIAMETER)	LENGTH OF CUT	OVERALL LENGTH	SINGLE CUT PART NUMBER	DOUBLE CUT PART NUMBER	ALUMINUM CUT PART NUMBER	SHANK DIAMETER
1/4	5/8	6-5/8	SL-1L6	SL-1L6D	-	1/4
3/8	1-1/16	7-1/16	SL-3L6	SL-3L6D	-	1/4
1/2	1-1/8	7-1/8	SL-4L6	SL-4L6D	-	1/4

**\*\* 3/8" shanks available \*\***

# POINTED CONE - SM SERIES

SM



## STANDARD SHANK LENGTHS

HEAD SIZE (DIAMETER)	LENGTH OF CUT	OVERALL LENGTH	SINGLE CUT PART NUMBER	DOUBLE CUT PART NUMBER	ALUMINUM CUT PART NUMBER	SHANK DIAMETER
3/32	1/4	1-1/2	SM-61	SM-61D	-	3/32
1/8	11/32	1-1/2	SM-41	SM-41D	-	1/8
1/8	7/16	1-1/2	SM-42	SM-42D	-	1/8
1/8	7/16	2	SM-42L2	SM-42L2D	-	1/8
1/8	7/16	3	SM-42L3	SM-42L3D	-	1/8
1/8	5/8	1-1/2	SM-43	SM-43D	-	1/8
3/16	1/2	2	SM-53	SM-53D	-	1/8
1/4	1/2	2	SM-51	SM-51D	-	1/8
1/4	1/2	2	SM-1	SM-1D	-	1/4
1/4	3/4	2	SM-2	SM-2D	-	1/4
1/4	1	2	SM-3	SM-3D	-	1/4
3/8	5/8	2-1/2	SM-4	SM-4D	-	1/4
1/2	7/8	2-3/4	SM-5	SM-5D	-	1/4
5/8	1	2-7/8	SM-6	SM-6D	-	1/4

\*\* 3/8" shanks available \*\*

# INVERTED TAPER - SN SERIES

SN



## STANDARD SHANK LENGTHS

HEAD SIZE (DIAMETER)	LENGTH OF CUT	OVERALL LENGTH	SINGLE CUT PART NUMBER	DOUBLE CUT PART NUMBER	ALUMINUM CUT PART NUMBER	SHANK DIAMETER
3/32	1/8	1-1/2	SN-61	SN-61D	-	3/32
3/32	1/8	1-1/2	SN-41	SN-41D	-	1/8
1/8	3/16	1-1/2	SN-42	SN-42D	-	1/8
3/16	1/4	1-3/4	SN-53	SN-53D	-	1/8
1/4	1/4	1-3/4	SN-51	SN-51D	-	1/8
3/16	1/4	2	SN-61	SN-61D	-	3/16
1/4	5/16	2	SN-1	SN-1D	-	1/4
3/8	3/8	2-1/8	SN-2	SN-2D	-	1/4
1/2	1/2	2-1/4	SN-4	SN-4D	-	1/4
5/8	3/4	2-1/2	SN-6	SN-6D	-	1/4
3/4	5/8	2-3/8	SN-7	SN-7D	-	1/4

\*\* 3/8" shanks available \*\*

Top Quality Carbide Burs from Grind-All Supply Ltd.



## Diamond Burs

Diamond  
Burs

**High Quality Diamond Burs  
available in various types and styles.  
Contact us with your needs!**



## Wheel Burs

Wheel  
Burs

**Grind-All Supply Ltd.  
offers a full line of  
diamond and carbide  
wheel burs and  
accessories!  
Contact us for details.**



Top Quality Products from Grind-All Supply Ltd.

## Heavy Duty Die Grinders

Die  
Grinders



**We carry a full line of Heavy Duty Die Grinders! Also, low speed die grinders for flexible spring shank burs. Many collet sizes available. Let us know what tools you're looking for!**

## Flex (Spring) Shanks

Flex  
Shanks

**Contact us for details on our flexible spring shanks - available with the custom bur head of your choice!**

**1/4" and 3/8" sizes available!**

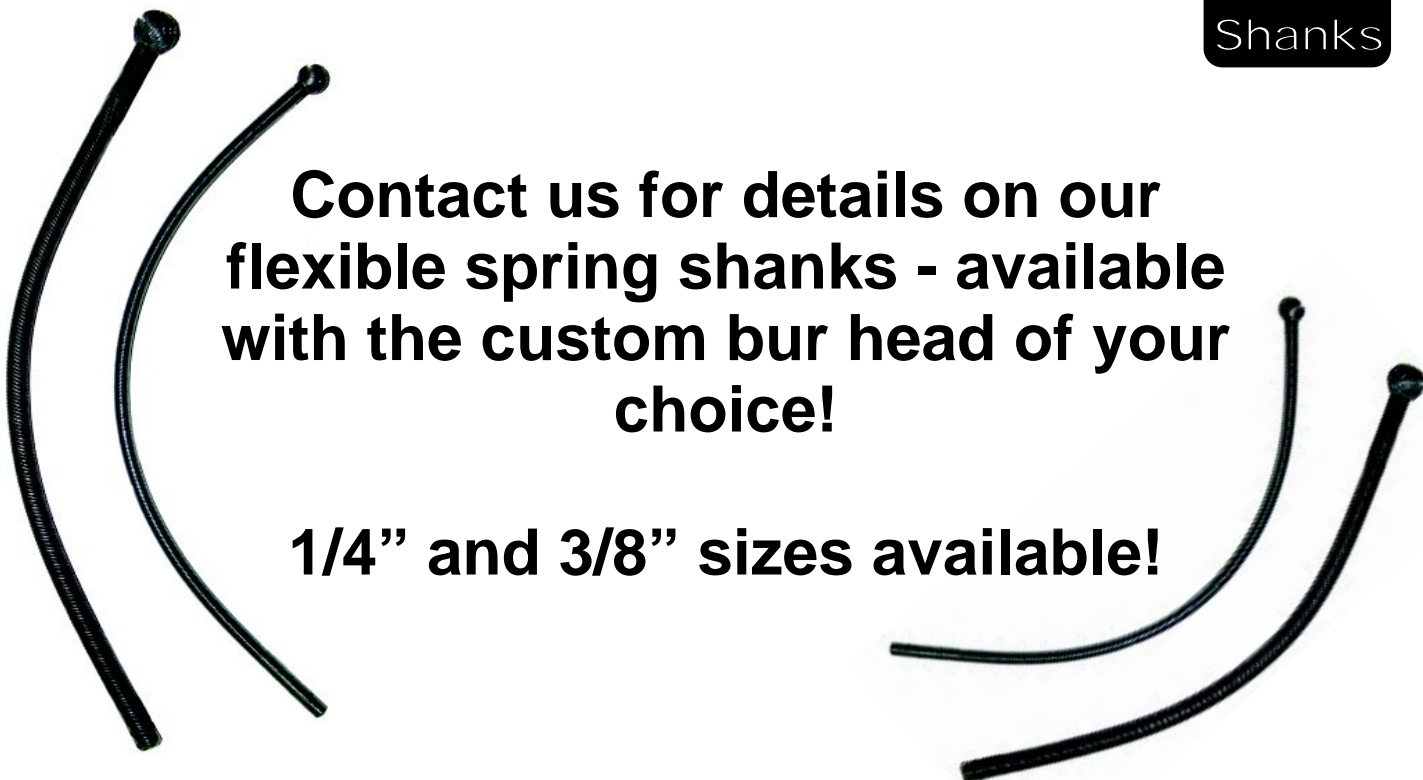

Top Quality Products from Grind-All Supply Ltd.

# Mini Chipping Hammer

Chipping Hammers

ONLY 10lbs!

## Mini 4 - BOLT CHIPPING HAMMER



We are proud to present the Mini 4-Bolt Chipping Hammer manufactured in North America with the highest quality materials and tightest tolerances. The Mini 4-Bolt delivers the power we promised for the Foundry Industry. Our patented two-step piston design cycles at 2,750 blows per minute and is ideal for cleaning castings and forgings, as well as refractory, gunite, and brick work. The rapid cycling rate delivers powerful blows to remove sand, slag, or ceramic from the impact zones and surrounding areas.

(Optional quick change retainer)



The Mini 4-Bolt hits harder than any other 10 lb. chipping hammer currently on the market. If you want to increase production, reduce downtime, and offer incentive to your workforce, then you want the Mini 4-Bolt chipper in your facility today. We realize your most valuable asset is your workforce. Offer your employees the best tool for the job. Give them the Mini 4-Bolt Chipping Hammer from Grind-All Supply. Give us a call today for more information or to purchase.

### Specifications

Stroke.....	2.6" (66mm)
Bore.....	1.1" (28mm)
Blows Per Minute (BPM).....	2750
Length.....	14 1/4"
Weight (w/ Retainer).....	10.5 lbs.
Air Inlet Thread.....	3/8" NPT
Model M4BLTH.....	0.580 Hex Shank
Model M4BLTR.....	0.680 Round Shank



**Hardest Hitting Chipping Hammers on the market! Made in USA**

Top Quality Products from Grind-All Supply Ltd.

# Full Size Chipping Hammer

Chipping  
Hammers

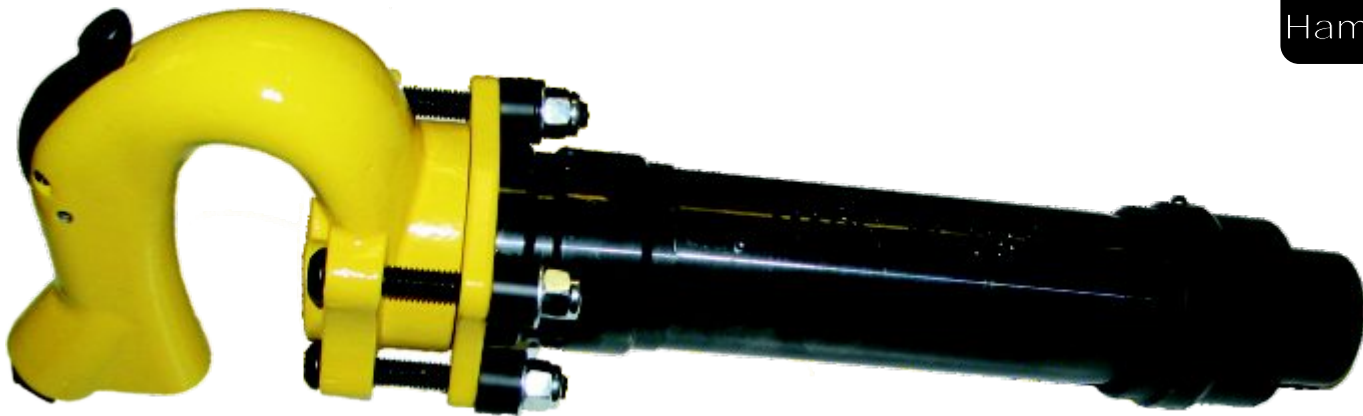

*NEW! Coming soon...*

~~X-TREME~~  
**FULL SIZE**



This new, unique, innovative full-size chipping hammer has a gooseneck style handle made of a special lightweight alloy. The bolt-on handle design has all the benefits of a typical bolt-on handle, except its gooseneck style allows large gloved hands to use with ease and comfort. This new handle does away with typical old-style bolt-on handles, which are awkward, clumsy, and heavier. This hammer hits 10% harder than other full-size chipping hammers. Its unique valve system also passes dirt better than conventional simplate valve systems. Contact us today for more information - or check our website!

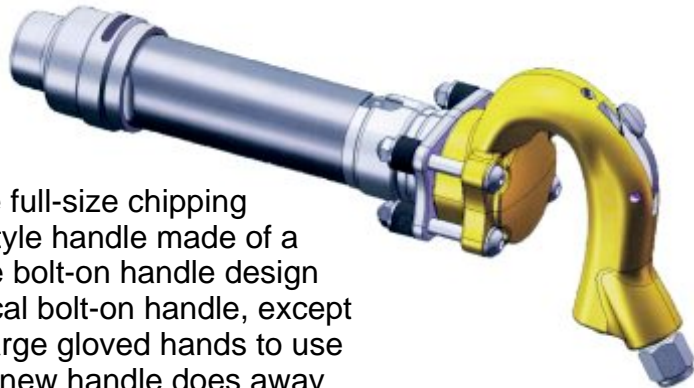

**No more tangled hoses! Air swivel available for chipping hammers!**

Top Quality Products from Grind-All Supply Ltd.

**Hardest Hitting Chipping Hammers on the market! Made in USA**

# Oval Collar Chipping Hammer Chisels





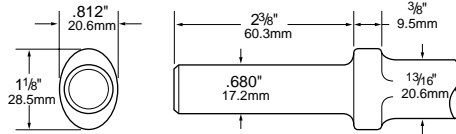

Chisels

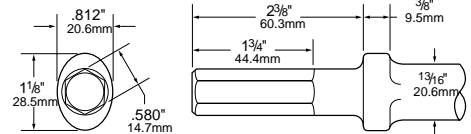
## .680 ROUND SHANK OVAL COLLAR

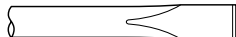
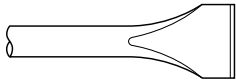
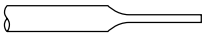

## .580 HEX SHANK OVAL COLLAR

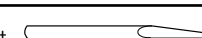
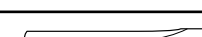
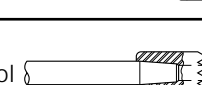

POINT STYLE	CAT.NO.	LENGTH	WIDTH	WT	CAT.NO.	LENGTH	WIDTH	WT
	301	8 1/4"	13/16" Dia.	1.25 lbs.	302	8 1/4"	13/16" Dia.	1.25 lbs.
	301-12	11 1/4"	13/16" Dia.	1.5 lbs.	302-12	11 1/4"	13/16" Dia.	1.5 lbs.
	301-18	18"	13/16" Dia.	2.5 lbs.	302-18	18"	13/16" Dia.	2.5 lbs.
	301-24	24"	13/16" Dia.	3.25 lbs.	302-24	24"	13/16" Dia.	3.25 lbs.
	313	9"	—	1.25 lbs.	314	9"	—	1.25 lbs.
	315	12"	—	1.5 lbs.	316	12"	—	1.5 lbs.
	315-18	18"	—	2.5 lbs.	316-18	18"	—	2.5 lbs.
	315-24	24"	—	3.25 lbs.	316-24	24"	—	3.25 lbs.
	303	9"	1"	1.25 lbs.	304	9"	1"	1.25 lbs.
	303-12	12"	1"	1.5 lbs.	304-12	12"	1"	1.5 lbs.
	303-18	18"	1"	2.5 lbs.	304-18	18"	1"	2.5 lbs.
	303-24	24"	1"	3.25 lbs.	304-24	24"	1"	3.25 lbs.
	303-36	36"	1"	5.1 lbs.	304-36	36"	1"	5.1 lbs.
	303-48	48"	1"	6.9 lbs.	304-48	48"	1"	6.9 lbs.
	303-60	60"	1"	8.7 lbs.	304-60	60"	1"	8.7 lbs.
	303-72	72"	1"	10.2 lbs.	304-72	72"	1"	10.2 lbs.
	325	9"	1 1/2"	1.25 lbs.	326	9"	1 1/2"	1.25 lbs.
	325-12	12"	1 1/2"	1.5 lbs.	326-12	12"	1 1/2"	1.5 lbs.
	325-18	18"	1 1/2"	2.5 lbs.	326-18	18"	1 1/2"	2.5 lbs.
	323	9"	2"	1.25 lbs.	324	9"	2"	1.25 lbs.
	323-12	12"	2"	1.75 lbs.	324-12	12"	2"	1.75 lbs.
	323-18	18"	2"	2.75 lbs.	324-18	18"	2"	2.75 lbs.
	323-24	24"	2"	3.75 lbs.	324-24	24"	2"	3.75 lbs.
	323-36	36"	2"	5.75 lbs.	324-36	36"	2"	5.75 lbs.
	323-48	48"	2"	7.75 lbs.	324-48	48"	2"	7.75 lbs.
	323-60	60"	2"	9.75 lbs.	324-60	60"	2"	9.75 lbs.
	323-72	72"	2"	11.75 lbs.	324-72	72"	2"	11.75 lbs.
	323-3	9"	3"	1.5 lbs.	324-3	9"	3"	1.5 lbs.
	323-12-3	12"	3"	1.75 lbs.	324-12-3	12"	3"	1.75 lbs.
323-4-1/2	10"	4 1/2"	2.25 lbs.	324-4-1/2	10"	4 1/2"	2.25 lbs.	
	311	9"	1 1/16"	1.0 lbs.	312	9"	1 1/16"	1.0 lbs.
	311-12	12"	1 1/16"	1.4 lbs.	312-12	12"	1 1/16"	1.4 lbs.
	305	9"	7/16"	1.0 lbs.	306	9"	7/16"	1.0 lbs.
	305-12	12"	7/16"	1.4 lbs.	306-12	12"	7/16"	1.4 lbs.
	307	9"	3/8"	1.0 lbs.	308	9"	3/8"	1.0 lbs.
	307-12	12"	3/8"	1.4 lbs.	308-12	12"	3/8"	1.4 lbs.
	309	9"	5/16"	1.1 lbs.	310	9"	5/16"	1.1 lbs.
	309-12	12"	5/16"	1.5 lbs.	310-12	12"	5/16"	1.5 lbs.
	337	9"	1"	1.1 lbs.	338	9"	1"	1.1 lbs.
	337-12	12"	1"	1.5 lbs.	338-12	12"	1"	1.5 lbs.
	343	9 1/2"	—	2.25 lbs.	344	9 1/2"	—	2.25 lbs.
	345 STEM	8"	—	1.0 lbs.	346 STEM	8"	—	1.0 lbs.
	5101 HEAD	—	1 1/2" SQ	1.25 lbs.	5101 HEAD	—	1 1/2" SQ	1.25 lbs.
	50100	9 1/2"	1 3/4" SQ	2.5 lbs.	50200	9 1/2"	1 3/4" SQ	2.5 lbs.

These chisels will fit Mini 4-Bolt & Xtreme chipper.

Top Quality Products from Grind-All Supply Ltd.

# Round Collar Chipping Hammer Chisels





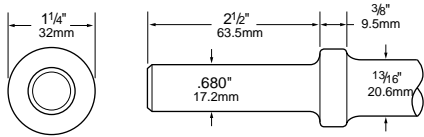

Chisels

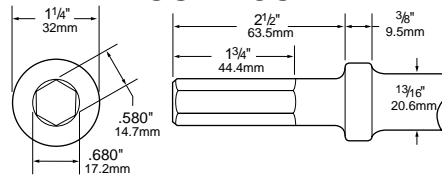
## .680 ROUND SHANK ROUND COLLAR

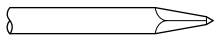
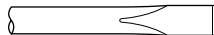
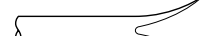

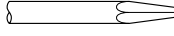
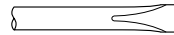
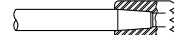
## .580 HEX SHANK ROUND COLLAR



CAT.NO.	LENGTH	WIDTH	WT	CAT.NO.	LENGTH	WIDTH	WT	POINT STYLE
401	8 1/4"	13/16" Dia.	1.25 lbs	402	8 1/4"	13/16" Dia.	1.25 lbs	Round Blank
403	11 1/4"	13/16" Dia.	1.5 lbs	404	11 1/4"	13/16" Dia.	1.5 lbs	
403-18	18"	13/16" Dia.	2.5 lbs	404-18	18"	13/16" Dia.	2.5 lbs	
409	9"	—	1.25 lbs	410	9"	—	1.25 lbs	Moil Point
411	12"	—	1.5 lbs	412	12"	—	1.5 lbs	
411-18	18"	—	2.5 lbs	412-18	18"	—	2.5 lbs	
411-24	24"	—	3.25 lbs	412-24	24"	—	3.25 lbs	
405	9"	1"	1.25 lbs	406	9"	1"	1.25 lbs	Flat Chisel
407	12"	1"	1.5 lbs	408	12"	1"	1.5 lbs	
407-18	18"	1"	2.5 lbs	408-18	18"	1"	2.5 lbs	
407-24	24"	1"	3.25 lbs	408-24	24"	1"	3.25 lbs	
407-36	36"	1"	5 lbs	408-36	36"	1"	5 lbs	
407-48	48"	1"	6 lbs	408-48	48"	1"	6 lbs	
407-60	60"	1"	8 lbs	408-60	60"	1"	8 lbs	
407-72	72"	1"	10 lbs	408-72	72"	1"	10 lbs	
425	9"	1 1/2"	1.25 lbs	426	9"	1 1/2"	1.25 lbs	Scaling Chisel
425-12	12"	1 1/2"	1.5 lbs	426-12	12"	1 1/2"	1.5 lbs	
425-18	18"	1 1/2"	2.5 lbs	426-18	18"	1 1/2"	2.5 lbs	
423	9"	2"	1.25 lbs	424	9"	2"	1.25 lbs	
423-12	12"	2"	1.75 lbs	424-12	12"	2"	1.75 lbs	
423-18	18"	2"	2.75 lbs	424-18	18"	2"	2.75 lbs	
423-24	24"	2"	3.75 lbs	424-24	24"	2"	3.75 lbs	
423-36	36"	2"	5.75 lbs	424-36	36"	2"	5.75 lbs	
423-48	48"	2"	7.75 lbs	424-48	48"	2"	7.75 lbs	
423-60	60"	2"	9.75 lbs	424-60	60"	2"	9.75 lbs	
423-72	72"	2"	11.75 lbs	424-72	72"	2"	11.75 lbs	
423-3	9"	3"	1.5 lbs	424-3	9"	3"	1.5 lbs	
423-12-3	12"	3"	1.75 lbs	424-12-3	12"	3"	1.75 lbs	
423-4-1/2	10"	4 1/2"	2.25 lbs	424-4-1/2	10"	4 1/2"	2.25 lbs	
413	9"	7/16"	1.0 lbs	414	9"	7/16"	1.0 lbs	Cape Chisel
413-12	12"	7/16"	1.4 lbs	414-12	12"	7/16"	1.4 lbs	
417	9"	3/8"	1.0 lbs	418	9"	3/8"	1.0 lbs	Round Nose
417-12	12"	3/8"	1.4 lbs	418-12	12"	3/8"	1.4 lbs	
419	9"	5/16"	1.1 lbs	420	9"	5/16"	1.1 lbs	Diamond Point
419-12	12"	5/16"	1.5 lbs	420-12	12"	5/16"	1.5 lbs	
437	9"	1"	1.1 lbs	438	9"	1"	1.1 lbs	Gouge
437-12	12"	1"	1.5 lbs	438-12	12"	1"	1.5 lbs	
443	9 1/2"	—	2.25 lbs	444	9 1/2"	—	2.25 lbs	2 Pc. Bush Tool
445 STEM	8"	—	1.0 lbs	446 STEM	8"	—	1.0 lbs	
5101 HEAD	—	1 1/2" SQ	1.25 lbs	5101 HEAD	—	1 1/2" SQ	1.25 lbs	1 Pc. Bush Tool
50300	9 1/2"	1 3/4" SQ	2.5 lbs	50400	9 1/2"	1 3/4" SQ	2.5 lbs	
429	16 3/4"	7/8"	2.1 lbs					Paper Stripper
431	18 1/4"	7/8"	2.2 lbs					Bent 
433	16 3/4"	7/8"	2.1 lbs					Straight 
435	18 1/4"	7/8"	2.2 lbs					

Top Quality Products from Grind-All Supply Ltd.

These chisels will fit Mini 4-Bolt & Xtreme chipper when equipped with round collar retainer.

# Non-Collar Chipping Hammer Chisels

Chisels



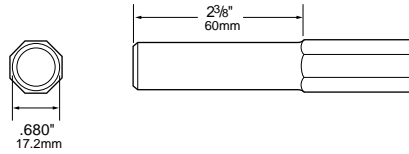

## .680 ROUND SHANK

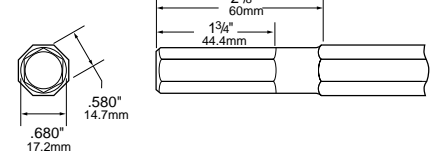

## .580 HEX SHANK

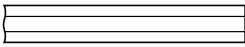
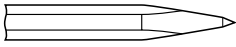

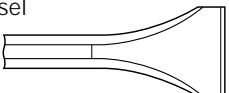
Top Quality Products from Grind-All Supply Ltd.

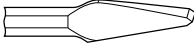
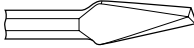
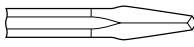
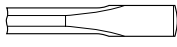
POINT STYLE	.680 ROUND SHANK					.580 HEX SHANK				
	CAT.NO.	STOCK SIZE	LENGTH	WIDTH	WT	CAT.NO.	STOCK SIZE	LENGTH	WIDTH	WT
Blank 	1	3/4"	8"	—	1 lb.	2	3/4"	8"	—	1 lb.
	1-12	3/4"	12"	—	1.4 lb.	2-12	3/4"	12"	—	1.4 lb.
	1-18	3/4"	18"	—	2.3 lb.	2-18	3/4"	18"	—	2.3 lb.
	1-24	3/4"	24"	—	3 lb.	2-24	3/4"	24"	—	3 lb.
	1-36	3/4"	36"	—	4.75 lb.	2-36	3/4"	36"	—	4.75 lb.
	1-48	3/4"	48"	—	6.25 lb.	2-48	3/4"	48"	—	6.25 lb.
	3	7/8"	8"	—	1.5 lb.	4	7/8"	8"	—	1.5 lb.
	3-12	7/8"	12"	—	2 lb.	4-12	7/8"	12"	—	2 lb.
	3-18	7/8"	18"	—	3 lb.	4-18	7/8"	18"	—	3 lb.
	3-24	7/8"	24"	—	4.25 lb.	4-24	7/8"	24"	—	4.25 lb.
3-36	7/8"	36"	—	6.5 lb.	4-36	7/8"	36"	—	6.5 lb.	
3-48	7/8"	48"	—	8.75 lb.	4-48	7/8"	48"	—	8.75 lb.	
Moil Point 	91	3/4"	9"	—	1 lb.	92	3/4"	9"	—	1 lb.
	93	3/4"	12"	—	1.4 lb.	94	3/4"	12"	—	1.4 lb.
	95	7/8"	9"	—	1.5 lb.	96	7/8"	9"	—	1.5 lb.
	97	7/8"	12"	—	2 lb.	98	7/8"	12"	—	2 lb.
Flat Chisel 	11	3/4"	9"	7/8"	1 lb.	12	3/4"	9"	3/4"	1 lb.
	11-12	3/4"	12"	7/8"	1.5 lb.	12-12	3/4"	12"	3/4"	1 lb.
	11-18	3/4"	18"	7/8"	2.3 lb.	12-18	3/4"	18"	3/4"	1 lb.
	11-24	3/4"	24"	7/8"	3 lb.	12-24	3/4"	24"	3/4"	1 lb.
	11-36	3/4"	36"	7/8"	4.75 lb.	12-36	3/4"	36"	3/4"	1 lb.
	11-48	3/4"	48"	7/8"	6.25 lb.	12-48	3/4"	48"	3/4"	1 lb.
	11-60	3/4"	60"	7/8"	8 lb.	12-60	3/4"	60"	3/4"	1 lb.
	11-72	3/4"	72"	7/8"	9.5 lb.	12-72	3/4"	72"	3/4"	1 lb.
	13	7/8"	9"	1"	1 lb.	14	7/8"	9"	1"	1 lb.
	13-12	7/8"	12"	1"	2 lb.	14-12	7/8"	12"	1"	1 lb.
	13-18	7/8"	18"	1"	3 lb.	14-18	7/8"	18"	1"	1 lb.
	13-24	7/8"	24"	1"	4.25 lb.	14-24	7/8"	24"	1"	1 lb.
	13-36	7/8"	36"	1"	6.5 lb.	14-36	7/8"	36"	1"	1 lb.
	13-48	7/8"	48"	1"	8.75 lb.	14-48	7/8"	48"	1"	1 lb.
13-60	7/8"	60"	1"	11 lb.	14-60	7/8"	60"	1"	1 lb.	
13-72	7/8"	72"	1"	13 lb.	14-72	7/8"	72"	1"	1 lb.	
Scaling Chisel 	25	3/4"	9"	2"	1.1 lb.	26	3/4"	9"	2"	1.1 lb.
	25-12	3/4"	12"	2"	1.6 lb.	26-12	3/4"	12"	2"	1.6 lb.
	25-18	3/4"	18"	2"	2.5 lb.	26-18	3/4"	18"	2"	2.5 lb.
	27	7/8"	9"	2"	1.7 lb.	28	7/8"	9"	2"	1.7 lb.
	27-12	7/8"	12"	2"	2.1 lb.	28-12	7/8"	12"	2"	2.1 lb.
	27-18	7/8"	18"	2"	3.25 lb.	28-18	7/8"	18"	2"	3.25 lb.
Thin Blade Flat 	35	3/4"	9"	1 1/8"	1 lb.	36	3/4"	9"	1 1/8"	1 lb.
	37	7/8"	9"	1 1/8"	1.5 lb.	40	7/8"	9"	1 1/8"	1.5 lb.
Cape Chisel 	21	3/4"	9"	7/16"	1 lb.	22	3/4"	9"	7/16"	1 lb.
	23	7/8"	9"	7/16"	1.5 lb.	24	7/8"	9"	7/16"	1.5 lb.
Round Nose 	31	3/4"	9"	3/8"	1 lb.	32	3/4"	9"	3/8"	1 lb.
	33	7/8"	9"	3/8"	1.5 lb.	34	7/8"	9"	3/8"	1.5 lb.
Diamond Point 	41	3/4"	9"	5/16"	1 lb.	42	3/4"	9"	5/16"	1 lb.
	43	7/8"	9"	5/16"	1.5 lb.	44	7/8"	9"	5/16"	1.5 lb.
Gouge 	51	3/4"	9"	1"	1 lb.	52	3/4"	9"	1"	1 lb.
	53	7/8"	9"	1"	1.5 lb.	54	7/8"	9"	1"	1.5 lb.

Hardest hitting scaler on the market!



**Heavy Duty Scalers and accessories available! Contact us for details.**

Top Quality Products from Grind-All Supply Ltd.

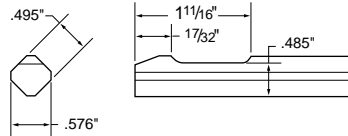

**INGERSOLL RAND  
STYLE SHANK**

## Scaling Hammer Chisels

CAT. NO.	LENGTH	WIDTH	WT	POINT STYLE	
381	7"	—	.4 lbs	Blank	
381-12	12"	—	.7 lbs		
381-18	18"	—	1.2 lbs		
382	7"	3/4"	.4 lbs	Flat Chisel	
382-12	12"	3/4"	.7 lbs		
382-18	18"	3/4"	1.2 lbs		
383	7"	1 3/8"	.4 lbs	Scaling Chisel	
383-12	12"	1 3/8"	.7 lbs		
383-18	18"	1 3/8"	1.2 lbs		
380	7"	2"	.5 lbs	Wide Scaling Chisel	
380-12	12"	2"	.8 lbs		
380-3	7 1/2"	3"	.8 lbs		
384	7"	1 3/8"	.4 lbs	Angle Chisel	
384-12	12"	1 3/8"	.7 lbs		
384-18	18"	1 3/8"	1.2 lbs		
3229	7"	5/16"	.4 lbs	Cape Chisel	
3228	7"	5/16"	.4 lbs	Round Nose Chisel	
3227	7"	1/4"	.4 lbs	Diamond Point	
3221	7"	—	.4 lbs	Single Blade Panel Cutter	
-	-	-	-	Heavy Blade Flat (Rounded Point)	

## **Contact Information...**

**Grind-All Supply Ltd.**

### **Canada**

271-A Stephen St.  
Morden, Manitoba  
R6M 1V2

### **United States**

1800 Hwy. 32 North  
Walhalla, North Dakota  
58282

**Ph:** (204) 822-9911

**Fax:** (204) 822-9912

**Email:** [info@grindall.ca](mailto:info@grindall.ca)

**Website:** <http://www.grindall.ca>

**Distributed by:**